

Technical Practice

Issue 1, February, 1994

MODEL 711 POWER SUPPLY

Contents

Section 1	General Description
Section 2	Applications
Section 3	Installation
Section 4	Testing and Operation
Section 5	Circuit Description
Section 6	Specifications
Section 7	Incorrect Operation
Section 8	Repair and Replacement



1. General Description

1.1 PRACTICE In the event that this practice is reissued, the reason for the reissue will be stated in this paragraph.

1.2 PRODUCT OVERVIEW The Model 711 Power Supply provides a filtered and regulated 12Vdc output with a maximum current of 2A. The nominal AC mains input power is 120V, 47 to 63Hz, with an operating range of 85 to 265V. The Model 711 is Underwriters Laboratories, Inc. Listed for 120V, 50/60Hz operation.

1.3 FEATURES Model 711 features include an LED indicator, wide mains voltage operating range, output short-circuit protection, and simple installation. An LED is provided as an installation, operation, and maintenance aid. This LED is referred to as the DC output LED. The wide mains voltage range, 85 to 265V, allows operation even when the mains power source deviates significantly from nominal. The Model 711's circuitry is designed for robust performance. The output is short-circuit and over-current protected, automatically returning to normal operation when the fault condition is removed. The unit is completely self-contained in a compact wall-mounted cabinet. DC-output interconnections are made using a 3-conductor removable screw terminal strip. Mains power is connected using a standard 3-conductor cord.

1.4 PHYSICAL DESCRIPTION The Model 711 consists of a precision-fabricated printed circuit board, enclosed in a painted steel enclosure. The Model 711's overall dimensions are 4.7 inches (11.9cm) high, 7.4 inches (18.7cm) wide, 2.3 inches (5.8cm) deep, and weighs 2.5 pounds (1.1kg). It wall mounts with two screws.

2. Applications

2.1 PRIMARY APPLICATION The Model 711 Power Supply is intended to serve a wide range of general purpose industrial and commercial applications.

2.2 FLOATING OUTPUT The Model 711 has a floating output, making it suitable to provide positive or negative ground-referenced DC voltage.

2.3 INTERNATIONAL USE The Model 711 is suitable for applications literally anywhere in the world. With a mains voltage range of 85 to 265V, 47 to 63Hz, the unit is perfect for installation in locations where the nominal mains voltage is 100, 120, 220, or 240V. Wide fluctuation in mains voltage and frequency is tolerated, with no effect on the output DC. With no switches to set, or straps to cut the Model 711 makes successful installations very simple.

2.4 UL LISTED The Model 711 has been tested and approved by Underwriters Laboratories, Inc. as a Listed power supply for 120V, 50/60Hz operation.

3. Installation

3.1 WORDS OF CAUTION As with any product, installing the Model 711 requires a safety-first approach. The Model 711 is intended for wall mounting only in a dry location.

3.2 CHECKING FOR DAMAGE The Model 711 should be inspected for damage immediately upon receipt. A claim should be filed with the shipper if damage is found. A replacement should be ordered if necessary.

3.3 INSTALLATION KIT Included in each Model 711 shipping carton is a mounting kit. Each kit contains two #8 pan-head screws (type A, 3/4-inch long).

3.4 SELECTING A MOUNTING LOCATION Because the Model 711 is intended for wall mounting only, you must select a suitable position on the equipment room wall, preferably on a wooden backboard. Two factors come into play as you select the “perfect” mounting: air flow and proximity to a mains power outlet. The openings must remain clear to allow adequate ventilation. Also, ensure that the cabinet is not located underneath terminal blocks where small pieces of wire could fall into the unit. The Model 711 contains a 6-foot (2-meter), 3-conductor mains power cord. Select a mounting location that allows convenient access to a grounded outlet.

3.5 MOUNTING THE UNIT Mount the Model 711 using the two screws supplied in the installation kit. These screws are intended for use with a wooden-backboard surface (minimum thickness 3/4 inch). The Model 711’s cabinet is outfitted with two keyhole screw slots. Use one screw per slot and securely fasten the unit to the backboard. Do not connect to mains power at this time. You will be instructed to do so later in this section.

3.6 DC OUTPUT CONNECTIONS Before connecting to the DC output ensure that mains power is not connected. Be certain that the DC output LED is not lit. The DC-output connections are made via a 3-position plug-in terminal strip. The terminal strip is located on the bottom face of the unit, adjacent to the where the mains power cord exits the chassis, as illustrated in Figure 1. Remove the terminal strip by firmly grasping it with your fingers and pulling it straight away from the cabinet. Do not wire the terminal strip while it is attached to the power supply. Once it is removed, a small straight-blade screwdriver is required to loosen the clamp screws. The interconnecting wires are slipped into the openings of the terminal strip, and then the screws are tightened to secure the wires into place. A minimum wire gauge of #18 AWG or larger is recommended. (Remember that the smaller the AWG number, the larger its current rating.) Although not required, using a wire that is “heavier” than is technically necessary will help to minimize the resistance, and the resultant voltage drop, between a power source and the equipment being powered. After the wires are secured into the terminal strip, plug it back into the socket on the Model 711. Ensure that the terminal strip is firmly mated with the socket.

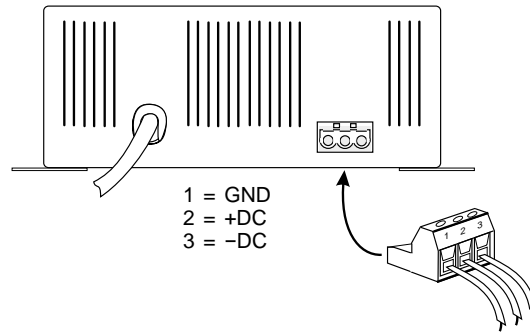

Figure 1 Model 711 cabinet showing 3-position plug-in terminal strip.

3.7 SELECTING THE DESIRED DC OUTPUT SCHEME As mentioned previously, the DC output is floating (isolated) in respect to earth ground. The DC output can be connected to the equipment to be powered in this manner, or it can be referenced to earth ground. A negative ground scheme, shown in Figure 2, is created by strapping pin 1 (ground) to pin 3 (-DC) and using this combination as the ground connection to the load. +12Vdc is then connected from pin 2 (+DC) to the load. Note that pin 1 is internally connected to the Model 711 chassis and the safety ground wire of the mains power cord.

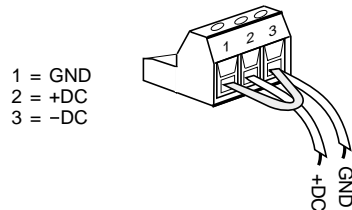

Figure 2 3-position terminal strip showing DC output connected for a negative ground scheme.

3.8 CONNECTING MAINS POWER Before the Model 711 is connected to the mains power source, ensure that all DC-output connections have been made. The Model 711 is shipped with a North American-standard plug attached to the mains power cord. In non-North American applications the appropriate plug must be attached. The mains cord conforms to the internationally recognized CEE color code and should be wired accordingly:

Connection	Wire Color
Neutral (N)	Light Blue
Line (L)	Brown
Protective Earth (E)	Green/Yellow

Once the correct plug is attached, mate the mains plug with the designated outlet. The DC output LED should light and the unit should be producing 12Vdc. Do not secure the mains power cord to the wall. It must hang free to allow rapid disconnection if circumstances require. Attaching the mains power cord to the wall surface creates a safety hazard and may be an electrical-code violation.

4. Testing and Operation

4.1 INSTALLATION REVIEW By this point, connections should have been made between the Model 711 and the equipment to be powered. The mains power cord should have been plugged into the selected outlet. Confirm that the mains power cord is hanging free and is not attached to the wall surface. The vents must be clear to allow air flow.

4.2 DC OUTPUT LED The DC output LED will light steadily any time mains power is supplied to the unit and 12Vdc is present on the output. If the LED does not light, or appears to flash rapidly, a wiring error exists. Check the installation and refer to Section 7 of this practice for troubleshooting assistance.

4.3 TESTING THE ASSOCIATED EQUIPMENT Now that 12Vdc is being produced, check each piece of equipment that is being powered. If possible, use a digital volt meter to check the output for nominal 12Vdc; a reading of 11.5 to 13Vdc would be considered normal.

4.4 PLACING THE MODEL 711 INTO SERVICE The Model 711 should now be ready for a long, uneventful life. Normal operation should find the DC output LED lit steadily.

4.5 MAINTENANCE The Model 711 requires no normal maintenance. It is recommended that the Model 711 be examined not less than once a year to ensure that the openings in the cabinet remain unobstructed. Long, reliable Model 711 life depends on its ability to stay cool. (This is not bad advice for all of us to live by!)

5. Circuit Description

5.1 GENERAL The circuit description is intended to familiarize you with the Model 711 for engineering and applications use. Repairs to the unit should not be attempted as they will expose you to dangerous voltage levels. Please refer to the block diagram, Figure 3, when reading this technical description.

5.2 FUSE In series with the mains power input is a fuse that limits the amount of current that can enter the unit. Should the unit experience a catastrophic failure the fuse will open. A fuse that opens (blows) indicates a serious problem with the unit, and factory service is required.

5.3 INPUT FILTERING From the mains power cord and fuse, mains power passes through an electromagnetic interference (EMI) filter. This filter limits the amount of high-frequency energy exiting the unit by way of the mains power cord. Across the mains power input is a transient suppressor which protects the units from short-duration, high-voltage power surges.

5.4 RECTIFIER AND FILTER From the EMI filter the mains power is full-wave rectified, then filtered to provide high-voltage DC.

5.5 PWM SWITCHING REGULATOR An integrated circuit, along with supporting components, forms a pulse-width modulator (PWM) switching regulator. Technically, the Model 711 implements a discontinuous mode flyback regulator. The operating frequency of the circuit is approximately 35kHz. Integral to the PWM circuit is a multiple input and output transformer. One input winding is driven by a field-effect transistor (FET) which is controlled by the PWM output. A second winding on the input side of the transformer provides a feedback signal which provides power for the PWM circuit, and supplies a macro output voltage control signal.

5.6 OUTPUT RECTIFIER AND FILTER The secondary of the transformer provides a step-down function, as well as isolation from the mains power source. A high-speed, high-efficiency rectifier is used to half-wave rectify the transformer's secondary. Capacitors are used to filter the rectified signal. It is at this point that the output DC is created. The DC output LED is connected to the circuit at this point.

5.7 OUTPUT VOLTAGE FEEDBACK AND CONTROL An optical coupler is used to send a scaled version of the output voltage back to the PWM circuit. This signal is used for precise control of the output voltage.

5.8 EMI FILTER A second EMI filter is implemented to limit the amount of high-frequency energy that leaves the unit by way of the DC-output terminals.

5.9 OPERATING CHARACTERISTICS Untold hours of hair pulling were spent optimizing the performance of the Model 711. An area of critical interest was the operating characteristics as the output load current approaches, meets, and exceeds the rated maximum. The unit will supply DC

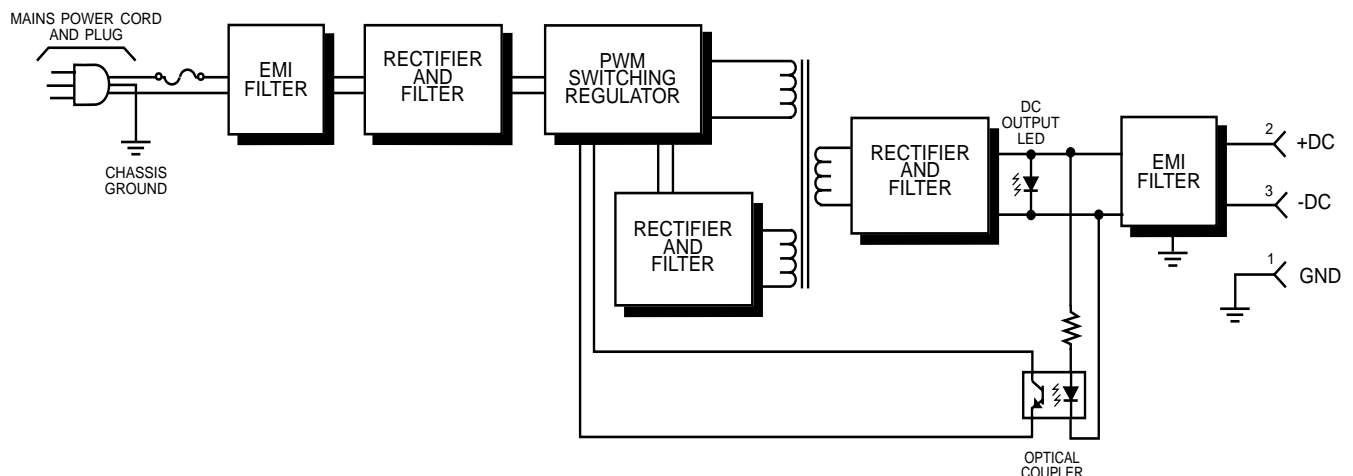

Figure 3 Model 711 Power Supply block diagram.

power that meets all specifications for regulation and noise up to the rated 2A output. At approximately 2.4A (120V mains power) the over-current threshold is reached, and the PWM circuit shuts down. The PWM performs a restart approximately every 120 milliseconds. The circuitry restarts but will continue operation only if the output load is within the normal range. Note that unlike some power supplies, the Model 711 does not have to have the load removed completely, or the mains power source disconnected, before the unit will restart. The Model 711 can have its output shorted indefinitely without damaging its circuitry. Every 120 milliseconds the DC output LED will "flash" as the circuit tries to restart. Remove the short and the output will return to 12Vdc.

5.10 NOMINAL OUTPUT VOLTAGE When reviewing the specifications you may note that the stated output voltage is 12.3Vdc, rather than 12.0Vdc. The output voltage was set a little higher than 12Vdc for a simple reason. When an installer measures the output voltage, receiving a reading of 12Vdc or greater (absolute value) is desirable. Normal manufacturing tolerances, voltage drop in connecting cables, etc. can lead to minor voltage drops. An installer seeing 11.8Vdc might be under the assumption that the "12Vdc" was low, even though in actuality a reading of even a few volts lower than 12Vdc would be acceptable. We felt that making it "look" better could prevent undue concern. This voltage setting, along with the excellent output regulation should keep the Model 711's output very close to 12Vdc under all normal operating conditions. We hope our attempt at amateur psychology will make life in the field a little less stressful!

5.11 DESIGN PHILOSOPHY With literally dozens of power supplies already on the market, you might be interested in why Gordon Kapes, Inc. went ahead and developed the Model 711 as part of a line of general-purpose power supplies. For years we have manufactured equipment that requires external sources of power. We assumed that getting standard power sources was inexpensive and simple. However, after we built some special systems we found that obtaining power supplies that we liked was not at all easy. Many were old designs that used linear technology, weighed a ton and generated considerable heat. Others were intended for table-top mounting, which isn't always convenient. One supply purported to be filtered and regulated, but how they made that claim we couldn't figure out! Others were quite good, excellent in fact, but were very pricey, didn't have the right output current, or were hard to install. So in the end we felt that if we were having problems, maybe you were too! The following paragraphs detail some of the Model 711's design highlights:

Clean, "Honest" 12Vdc Output: The Model 711's output is a high-quality DC signal suitable for virtually any application (within the rated load). The nominal 12Vdc output varies little with changes in mains voltage and output load. In fact, over the rated 85 to 265V range you should measure no change in output voltage. Tight output load regulation keeps the output voltage close to 12Vdc. From no load to full load you'll find less than 0.5 volt difference.

Non-Detachable Mains Power Cord: A non-detachable mains power cord was selected so that the Model 711's input power could not accidentally become unplugged. Using a detachable 3-conductor mains power cord would

be less costly from a manufacturing standpoint, look more "high-tech," but wouldn't best serve the Model 711.

Single Output Voltage: Some power supplies allow you to select the output voltage, such as 12 or 24Vdc. While this is convenient for the manufacturer, purchasing agents, and warehouses, we felt that having a selectable output voltage is not worth the potential downside. We have seen too many pieces of equipment get ruined simply because a switch was set to the wrong position. With the Model 711 you get a clearly labeled 12Vdc, 2A power supply. If your installation requires a different voltage, simply select a different Gordon Kapes, Inc. power supply unit, such as the Model 712 which provides 24Vdc, 1A.

Easy Installation: Some power supplies are difficult to mount, requiring adapter brackets or special enclosures. Other units make you remove the cover to allow connection to the DC output. Not so with the Model 711. The unit wall mounts using just two screws; we even provide the screws! A detachable screw terminal strip gives easy access to the DC output. Once installed, the DC output LED tells you that output voltage is present, or if the unit is in the over-current mode.

Smart Handling of Overloads and Short Circuits: Making the Model 711 "bullet proof" was probably the most important requirement. Overloads and shorts are a fact of life in the real world. (A fact that some power supply manufacturers seem to forget!) Some power supplies have the bad manners to blow a fuse if their output is shorted. (Not too good if you don't have a replacement fuse.) Others shut down and require their mains power cord to be unplugged, then again plugged in before they'll restart. Still others require the output load to be disconnected before they'll restart. As you might expect, the Model 711 behaves very nicely under duress. A continuous load of 2A is perfectly acceptable, however if the output current exceeds 2.4A (with 120V mains power) the unit will shut down, with the output voltage dropping to 0. Several times each second the Model 711 will try to restart. The unit can continue in this mode indefinitely without damage. Once the load is brought to within the rated 2A range the output will again return to nominal 12Vdc. The mains power cord does not have to be disconnected, nor the output load removed, for restart to occur.

Part of a Power Supply Family: In addition to the Model 711, Gordon Kapes, Inc. offers a number of power supply units with output voltages and currents to meet a wide range of requirements. Units are available which provide 12, 24, and 48Vdc. In addition, units are also available that provide nominal 87V, 20Hz sine-wave ringing voltage for telecommunication applications. Contact Gordon Kapes, Inc. for details.

6. Specifications

MAINS INPUT POWER
85-265V, 47-63Hz, single phase

MAINS CURRENT
0.6A rms steady state, maximum.

MAINS POWER CORD
3-conductor with North American-standard plug, length 6 feet (2 meters), nominal, not detachable

OUTPUT VOLTAGE
12.3 ±0.5Vdc (with 100mA minimum load)

OUTPUT CURRENT
2A maximum, continuous

OUTPUT CURRENT FOR AUTOMATIC SHUTDOWN
2.4A, nominal (with 120V mains power)
3.5A, nominal (with 240V mains power)

MINIMUM LOAD CURRENT FOR OPTIMAL REGULATION
100mA

LOAD REGULATION
Less than 1%, load current 100mA to 2A, mains voltage 85 to 265V

OUTPUT RIPPLE VOLTAGE
Less than 10mV rms, maximum

INPUT TO OUTPUT EFFICIENCY
Greater than 85% at full load

OUTPUT CONNECTIONS
3-position detachable screw terminal strip

TRANSIENT PROTECTION
Input and output protected against transients

LED INDICATOR
Qty 1, indicates DC output

OPERATING ENVIRONMENT
-10 to 50 degrees C, humidity to 95% (no condensation)

RADIATED NOISE COMPLIANCE
Complies with U.S.A. FCC Part 15, subpart J, class A for radiated and conducted emissions

RELIABILITY
MTBF: 65 years, per Method 1 of Bellcore
TS-TSY-000332, Issue 3, September 1990

SAFETY COMPLIANCE
Underwriters Laboratories, Inc. Listed Power Supply for 120V, 50/60Hz operation

DIMENSIONS
4.7 inches high (11.9cm)
7.4 inches wide (18.7cm)
2.3 inches deep (5.8cm)

WEIGHT
2.5 pounds (1.1kg)

MOUNTING
Wall mounted only using two #8 pan head screws

7. Incorrect Operation

7.1 REVIEW PRACTICE Should problems arise in the operation of the Model 711, please review Section 3 Installation and Section 4 Testing and Operation in this practice.

7.2 MAINS POWER If the DC output LED does not light at all, confirm that the mains power is functioning by plugging another piece of equipment into the outlet. If the outlet is okay, but the DC output LED doesn't light, the Model 711 needs to be returned to the factory for repair.

7.3 OUTPUT OVERLOAD OR SHORT CONDITION If the DC output LED flashes rapidly an overload condition is being placed on the Model 711. This will occur whether the output is being shorted, or has a load that is attempting to draw more than 2A. Carefully recheck the wiring and equipment being powered. "Shed" some of the load to ensure an overload is not present. Once an acceptable load is connected the Model 711 will restart and the DC output LED will light steadily.

7.4 WIRING ERRORS If the Model 711's DC output LED is lighting steadily but the equipment being powered does not function correctly: check the interconnecting wiring for errors.

7.5 INTERNAL FUSE The Model 711 contains an internal fuse which is electrically in series with the mains power. This fuse will blow only if the unit experiences serious trauma. A blown fuse *always* indicates that the unit must be returned to the factory. The fuse is soldered into the circuit board and is not intended for user replacement. Removing the cover will expose you to hazardous voltages.

7.6 APPLICATION LIMITATIONS The Model 711 was designed to operate correctly in most applications. However, Gordon Kapes, Inc. does not guarantee the Model 711 to be compatible with every specific application. All functions of the installed Model 711 should be thoroughly tested before the unit is placed into service.

7.7 SAVE TIME You are encouraged to call Gordon Kapes, Inc. for technical support. We do not mind "walking" you through an installation, or performing a verbal review prior to your actually getting started. Please have these items with you: a copy of this technical practice, system configuration documentation, and adequate tools, including a digital volt-ohm meter (VOM). Our favorite meter is the excellent Fluke 70 or 80 series.

8. Repair and Replacement

8.1 NOT SO FAST Statistically, most equipment returned to Gordon Kapes, Inc. for repair actually has nothing wrong with it. A telephone call to Gordon Kapes, Inc. technical support can often help to get the equipment operating correctly. We don't mind spending time with our customers getting a site up and running.

8.2 SEND IT BACK If you determine that the Model 711 is defective, return for repair or replacement according to the Gordon Kapes, Inc. Warranty/Repair and Return policy. Like the big guys, we require that you obtain a return authorization number prior to returning any equipment.

8.3 ONLY WE FIX IT In the event repairs are ever needed on your Model 711, they should only be performed by Gordon Kapes, Inc. or an authorized representative. Do not remove the cover as it will expose you to hazardous voltages.

Specifications and information contained in this technical practice subject to change without notice.

© Gordon Kapes, Inc., February 11, 1994
all rights reserved
www.gkinc.com
support@gkinc.com